

VER.	AMENDMENT	AUTHORISED BY	DATE
2	REPLACEMENT PLAN	ABC	

TYPE FREEHOLD		
PURPOSE INTEREST		
PLAN OF EASEMENTS AND/OR OTHER INTERESTS OVER LOT 198 ON DP 31688		
SSA YES/NO		
DISTRICT CANNING	FILE	
TOWNSITE		
LOCAL AUTHORITY TOWN OF EAST VICTORIA PARK		
LOCALITY EAST VICTORIA PARK		
FORMER TENURE	ON INDEX BG34 (2) 15.20	
FIELD BOOK		
SCALE @ A3 ALL DISTANCES ARE IN METRES	1:300 3 0 3 6 9 12 15	
SURVEYOR'S CERTIFICATE - Reg 54 I hereby certify that this plan is accurate and is a correct representation of the (a) * survey; and/or (b) * calculations from measurements [* where applicable] undertaken for the purposes of this plan and that it complies with the relevant written law(s) in relation to which it is lodged	SURVEYOR'S CERTIFICATE - Compiled I hereby certify that this compiled plan (a) is a correct and accurate representation of the survey(s) of the subject land and (b) is in accordance with the relevant written law in relation to which it is lodged	
Licensed Surveyor	Date	
Licensed Surveyor	Date	
LOGGED	TYPE OF VALIDATION	SURVEY FIRM
DATE	FULL AUDIT
.....	LEGAL COMPONENT	APPROVED BY
FEE PAID	DOCKET	WESTERN AUSTRALIAN PLANNING COMMISSION
.....	CERTIFIED CORRECT	FILE
ASSESS No.	I.S.C.
.....	F.S.C.	Delegated Under S.16 P & D Act 2005
IN ORDER FOR DEALINGS		
SUBJECT TO		
.....		
.....		
.....		
.....		
FOR INSPECTOR OF PLANS & SURVEYS/ AUTHORIZED LAND OFFICER		
DATE		
APPROVED		
.....		
INSPECTOR OF PLANS & SURVEYS/ AUTHORISED LAND OFFICER		
DATE		

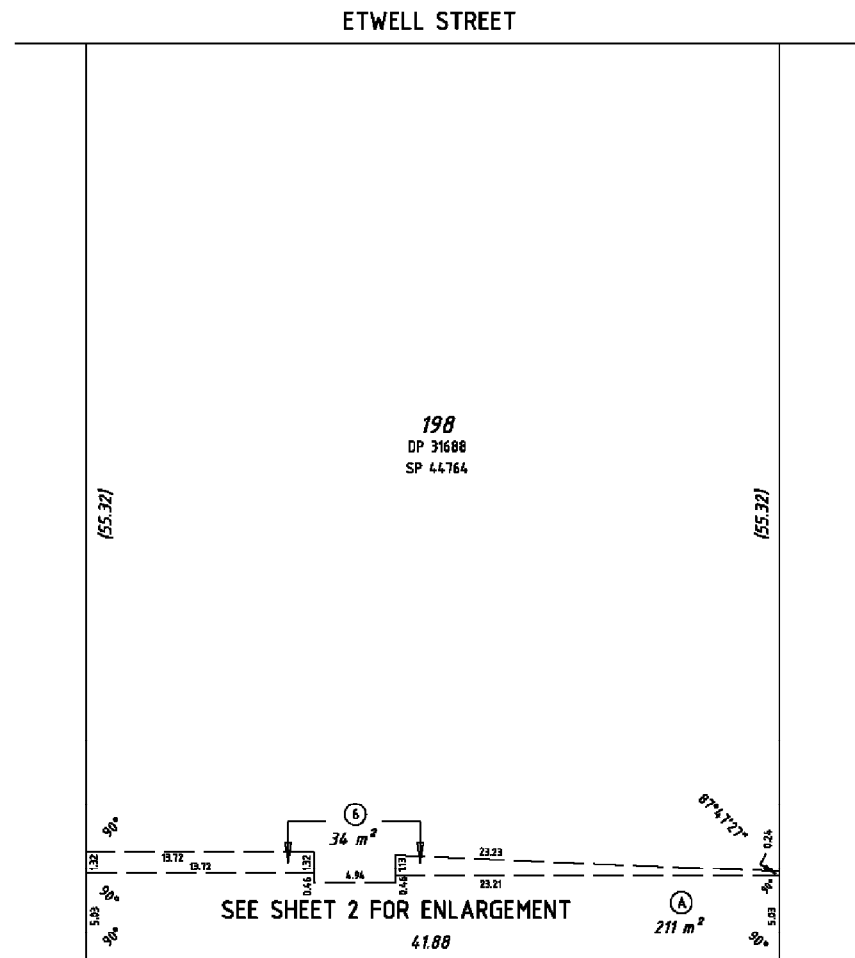

FOR INTEREST PURPOSES ONLY

INITIAL INTERESTS

SUBJECT	PURPOSE	STATUTORY REFERENCE	ORIGIN	LAND BURDENED	BENEFIT TO	COMMENTS
(A)	EASEMENT (SEWERAGE)		DOC(A531921) DOC(A531919)	SEE DOCUMENT SEE DOCUMENT	METROPOLITAN WATER SUPPLY SEWERAGE AND DRAINAGE BOARD	PARTIALLY SURRENDERED BY DOC
(B)	EASEMENT (SEWERAGE)	SECTION 167 OF THE P & D ACT REG 6	DP 31688	LOT 198	WATER CORPORATION	PARTIALLY EXTINGUISHED BY DOC



Western Australian Land Information Authority

DEPOSITED PLAN

EXAMPLE 91.1

SHEET 1 OF 2

VERSION .. 2 ..

FOR HEADING SEE SHEET 1

120
P 28231(2)

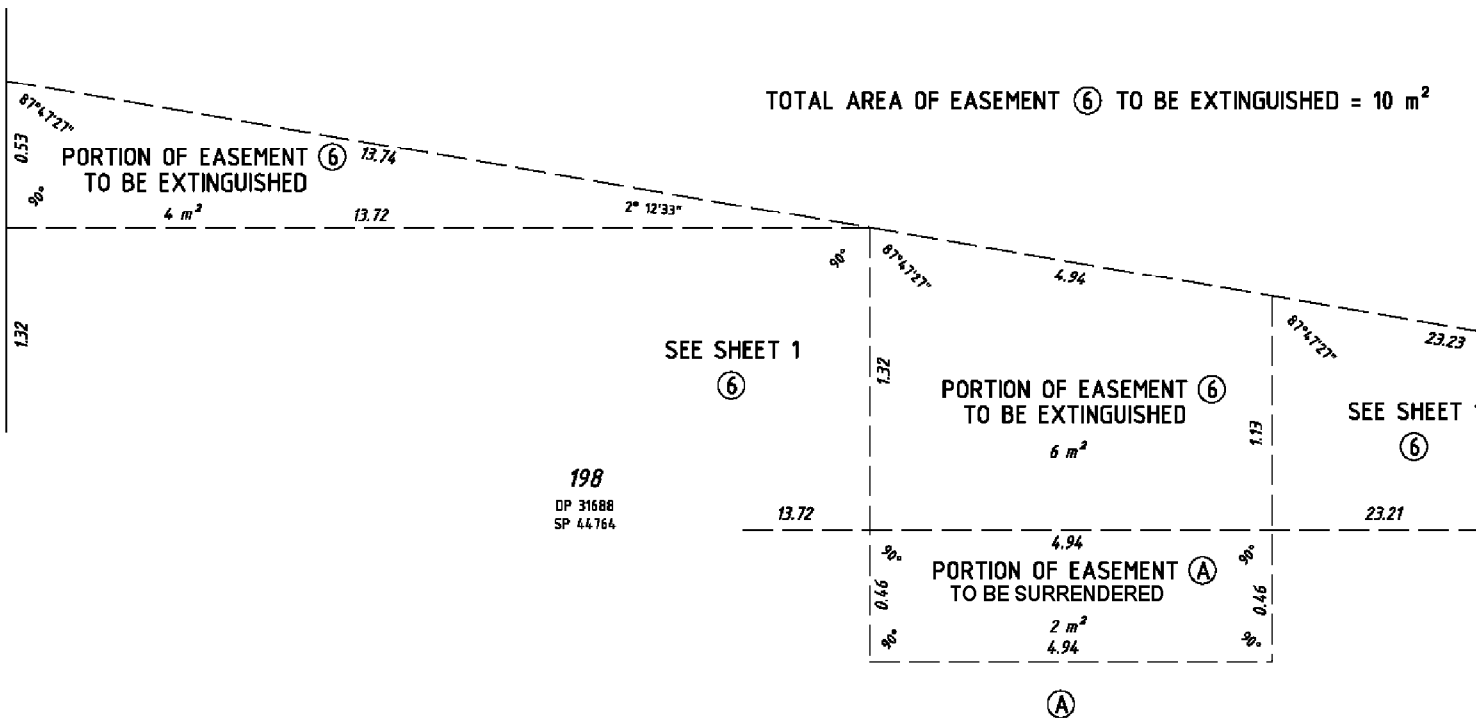

TOTAL AREA OF EASEMENT (6) TO BE EXTINGUISHED = 10 m²

SEE SHEET 1
(6)

SEE SHEET 1
(6)

(A)

SCALE @ A3
ALL DISTANCES
ARE IN METRES

NOT TO SCALE

Licensed Surveyor Date

APPROVED BY
WESTERN AUSTRALIAN PLANNING COMMISSION

FILE

Delegated Under S. 16 P & D Act 2005

DATE

SHEET ...?... OF ...?...

VERSION ...?...



Western Australian Land Information Authority

DEPOSITED PLAN

EXAMPLE 91.2